



# Terex Franna AT-20

Load chart

ABN : 86 010 671 048  
ACN : 010 671 048  
E-Mail : [info@terex.com.au](mailto:info@terex.com.au)  
Internet : [www.terex.com.au](http://www.terex.com.au)



**TEREX | FRANNA**

Terex Lifting Australia Pty. Ltd.



Quality  
Endorsed  
Company  
ISO 9001  
QEC10610

# **RATED CAPACITY MANUAL**

## **MODEL AT-20**

BOOK PART NUMBER 16C1320-

# **HYDRAULIC ALL TERRAIN PICK & CARRY CRANE**

## **20 TONNE MAXIMUM CAPACITY**

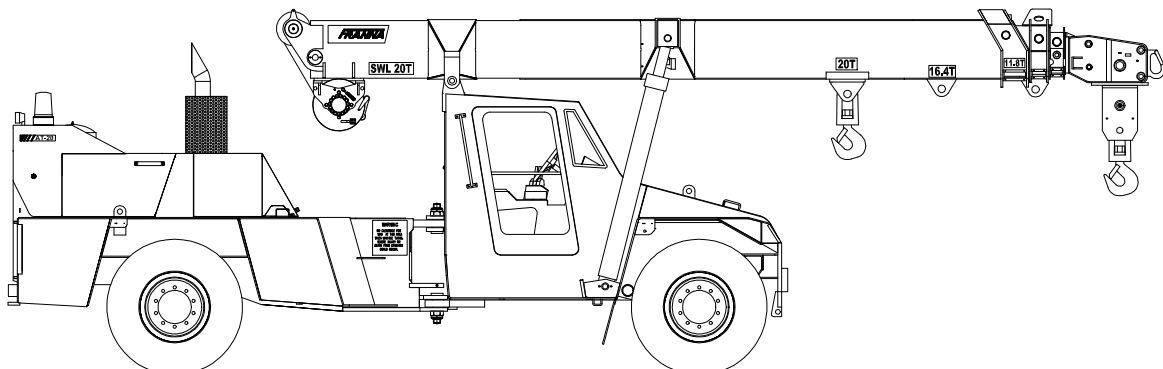

**Do not operate this  
crane unless you have  
read and understood  
the information in this  
book.**

# 16C1320- RATED CAPACITY MANUAL AT-20

ALL PAGES LISTED MUST BE INCLUDED IN THIS BOOK.

Page No.	Description
	RATED CAPACITY MANUAL MODEL AT-20
0-1	MODEL NUMBER INDEX
0-2	PAGE LIST
	SECTION 1 – WARNINGS
1-1	INDEX, SECTION 1
1-2	CAUTION
1-3	DEFINITIONS
1-4	WARNINGS, PAGE 1
1-5	WARNINGS, PAGE 2
1-6	WARNINGS, PAGE 3
1-7	OPERATION ON SIDE SLOPES
1-8	SIDE SLOPE DERATION CHART
	SECTION 2 – OPERATION
2-1	INDEX, SECTION 2
2-2	RANGE DIAGRAM & WORKING AREA DIAGRAM
2-3	ATTACHMENT MASSES, HOOK BLOCK RC, TYRE SPECIFICATIONS & TYRE INFLATION CHART
	SECTION 3 – LIFTING CAPACITY
3-1	LMI CODES
3-2	RANGE DIAGRAM
3-3	LMI DUTY 01 : WINCH - POWERED SECTIONS
3-4	LMI DUTY 03 : WINCH – MANUAL EXTENSION
3-5	LMI DUTY 02 : RHINO HOOK - POWERED SECTIONS
3-6	LMI DUTY 04 : RHINO HOOK – MANUAL EXTENSION
3-7	LMI DUTY 05 & 6 : FLYJIB (0° OFFSET)
3-8	LMI DUTY 07 & 8 : FLYJIB (12.5° OFFSET)
3-9	LMI DUTY 09 : FIXED LUG ON BUTT
3-10	LMI DUTY 10 : INNER LUG ON FIRST EXT.
3-11	LMI DUTY 11 : OUTER LUG ON FIRST EXT.
3-12	LMI DUTY 12 & 13 : MAN BASKET

# **SECTION 1**

# **WARNINGS**

CAUTION NOTE  
ATTACHMENT NOTICE  
DEFINITIONS  
WARNINGS  
OPERATION ON SIDE SLOPES

# **! CAUTION !**

IMPROPER CRANE USE, CARE OR OPERATION CAN CAUSE INJURY, DEATH OR PROPERTY DAMAGE.

DO NOT OPERATE THIS MACHINE UNLESS YOU HAVE READ AND UNDERSTAND THE OPERATOR'S MANUAL AND CRANE RATED CAPACITY MANUAL.

COPIES OF OPERATOR'S MANUALS AND CRANE RATED CAPACITY MANUAL MAY BE OBTAINED FROM:



**TEREX | FRANNA**

# **NOTICE**

WRITTEN AUTHORISATION IS REQUIRED FROM TEREX LIFTING AUSTRALIA PTY LTD PRIOR TO THE USE OF ANY ATTACHMENT NOT SPECIFIED IN THE MANUAL.

# DEFINITIONS

**Articulation** – The crane pivots in the middle to allow steering and slewing of the load. Working Areas for the purpose of determining Rated Capacity are less than 10° Articulation, and greater than 10° Articulation, in either direction, from straight ahead. Up to 40° Articulation is possible in either direction. See *Working Area diagram*

**Deration** – A decrease in the Rated Capacity due to external influences, expressed as a percentage.

**Freely Suspended Load** – Load hanging free with no direct external force applied except by the winch rope.

**Load Radius** – Horizontal distance from the centre of the front wheels forwards to the centre of the winch rope or tackle with load applied. “Radius” on Rated Capacity charts refers to the Load Radius in metres.

**Loaded Boom Angle** – This is given to assist in setting up the crane only. It gives only an approximation of the Load Radius for a specified boom length. No allowance is made for boom or tyre deflection. “Boom Angle” on Rated Capacity charts refers to the Loaded Boom Angle in degrees.

**Load Moment Indicator (LMI)** - A system that indicates, visually and audibly, to the operator when the Rated Capacity is approached and reached.

**Rated Capacity (RC)** – The total Freely Suspended Load, including the mass of material and load handling equipment, that the machine can safely lift under ideal conditions at a given boom length and Load Radius.

**Side Load** – Any external force applied either to the boom or load in a horizontal direction.

**Work Areas** – Area measured in an arc about the centre pivot as shown on the Working Area diagram. The “Articulation (green/amber)” icon on the LMI indicates which zone the crane is in. Green indicates less than 10° Articulation. Amber indicates greater than 10° Articulation.

# ! WARNING !

## SPECIAL PRECAUTIONS FOR ARTICULATED CRANES

THERE IS A POTENTIAL FOR CRUSHING BETWEEN FRONT AND REAR CHASSIS WHEN THE MACHINE ARTICULATES. NEVER STAND IN THE PIVOT AREA WHEN THE ENGINE IS RUNNING OR EMERGENCY STEERING PUMP IS OPERATING. ALWAYS REMOVE THE KEY FROM THE IGNITION BEFORE WORKING IN THE PIVOT AREA.

DO NOT LEAVE IGNITION KEY SWITCHED ON WITH ENGINE STOPPED AND PARK BRAKE OFF, AS EMERGENCY HYDRAULIC STEERING PUMP WILL ACTIVATE.

## GENERAL

1. This machine has been designed to meet the requirements of AS1418.1 & 1418.5 and has been tested in accordance with these standards for pick and carry operation on tyres.
2. Rated Capacities shown are for this machine as originally manufactured by Terex Lifting Australia Pty Ltd. The Rated Capacities only apply when all the instructions in this book are rigidly followed. Modifications to this machine or use of equipment other than that specified can result in a reduction in Rated Capacity.
3. If improperly operated or maintained, this machine can be hazardous. Operation and maintenance of this machine must be in compliance with the information documented in the operators, service and parts manuals furnished. If these manuals are missing, obtain replacements through Terex Lifting Australia Pty Ltd or their agents.

## SET-UP

4. Reduced crane Rated Capacities for the particular job shall be established, by the operator, with due allowance for adverse operating conditions. These conditions include the supporting surface, pendulum action of the load, jerking or sudden stops of the load and other factors affecting stability, two machine lifts, electrical wires, adverse weather, wind, hazardous surroundings, experience of personnel, etc.
5. Rated Capacity is based on Freely Suspended Loads with the machine on a firm, level (max. 1% slope / 0.6°) and uniform surface. Lifting, or travelling with a load, on soft or uneven ground can be hazardous and will reduce the Rated Capacity of the crane. Refer to the "OPERATION ON SIDE SLOPES" in this manual. No attempt shall be made to drag the load along the ground in any direction.
6. Wind forces on the boom, resulting from winds up to 10 m/s (36 km/h), are incorporated in the Rated Capacity. Any additional Side Loading due to wind forces on the load will reduce the Rated Capacity, and must be considered.

# ! WARNING !

7. Rated Capacities above the red line are based on the machine's hydraulic or structural competence and not on machine stability. Rated Capacities below the red line are based on machine stability.
8. Rated Capacities include the mass of hooks, blocks, slings and auxiliary lifting devices. Their mass must be subtracted, from the listed Rated Capacity, to determine the equivalent net load.
9. Loaded Boom Angles at specified boom lengths give only an approximation of the Load Radius. The Boom Angle before loading should be greater to account for boom deflection increasing the Load Radius as the load is lifted.

## OPERATION

10. Read and understand all warnings and instructional notes.
11. Do not tip the machine to determine allowable lifting capacities.
12. Loads may be lifted from the main boom head on the winch, the rhino hook, the fixed lug, or either of the two sliding lugs on the boom. A flyjib is also available to extend the maximum boom length and a manbasket can be pinned to the head of the boom. Always use the correct Rated Capacity chart for the lifting point in use and ensure the LMI is set to the correct duty. Written authorisation from Terex Lifting Australia Pty Ltd is required prior to the use of any attachment not specified in the manual.
13. Lifting from more than one lifting point simultaneously is neither intended nor approved.
14. Handling of personnel from the boom is neither intended nor approved, except in a Terex Lifting Australia supplied manbasket, correctly installed on the head of the boom, or other approved arrangement.
15. When either the boom length or Load Radius or both are between values listed, the smallest load shown at either the next larger Load Radius or boom length shall be used, or the interpolated value shown on the LMI may be used.
16. Side Loading of the machine and load swing out may cause structural failure or machine tip-over. Side Loads may be generated by: lifting when not level; sudden acceleration or deceleration in Articulating with a load; dragging a load; pushing a load; wind forces on load and boom structure.
17. Rated Capacity of the manual extension is determined by Loaded Boom Angle. The boom may be retracted and extended with the manual set, however, the Rated Capacity does not change from the fully extended position for the given Loaded Boom Angle.
18. It is safe to attempt to telescope any load within the limits of the Rated Capacity Manual. The maximum load that may be telescoped is limited by hydraulic pressure, Loaded Boom Angle and powered boom sections lubrication.

# ! WARNING !

19. The winch rope is fully compensated for boom extension. The only exception is when the manual extension is being set. Refer to the operator's manual for the manual setting procedure. Once it is set the compensation is fully functional.
20. Do not allow the winch rope to unwind fully. Always ensure a minimum of 2 wraps of rope remain on the winch drum. Note the areas on the range diagram where the fall block cannot reach the ground on 4 or 3 parts of rope.
21. Rated Capacity depends on tyre rating, tyre condition and tyre inflation pressure. All tyres must be in good condition and must be inflated to the recommended pressure before attempting a lift.
22. Pick & carry operation is permitted through the full Articulation range, however, Rated Capacity is reduced above 10° Articulation. Use the reduced capacities in the chart if entering this Articulation zone during the operation.
23. The maximum speed for pick & carry operation is 0.4m/s (1.44km/h). The transfer case shall be set to low range.
24. Operation of this crane in excess of the Rated Capacity and disregard of the instructions is hazardous.

# OPERATION ON SIDE SLOPES

Mobile Cranes are primarily designed to be used on firm, flat, level ground (to within 1% gradient), according to AS 1418.5, any deviation from this requires that the Rated Capacity shall be reduced accordingly. As per AS 2550.5 – negotiation of slopes by mobile cranes travelling with Freely Suspended Loads should be avoided. The following precautions should be taken when operating on side slopes of up to 5° (8.75% gradient) – **REMEMBER** surface depressions and potholes will create the same effect as a side slope.

- Ensure the tyres are correctly **INFLATED** as per the rated capacity manual.
- Ensure the ground condition is **FIRM** enough to support the axle loads.
- **REDUCE** the Rated Capacity of the crane by the percentage value for the crane as shown in figure 1 for operating on side slopes up to 5° (8.75% gradient) - **REMEMBER** the crane's load indicator will **NOT** automatically derate the Rated Capacity.
- Use the crane's side slope inclinometer as a guide only, it is most accurate when the crane's Articulation is straight ahead without suspending a load. All Articulated chassis cranes will show some degree of side tilt, when Articulated with a load – this should not be confused with the ground's side slope.
- Use the **MINIMUM** boom length and Loaded Boom Angle practical to keep the boom tip as close to the ground as possible.
- Keep the load as **CLOSE** to the ground as possible.
- Use the **MINIMUM** Articulation angle practical - **REMEMBER** the crane will side tilt and hence the hook will move towards the direction of Articulation whilst steering.
- Keep the load on the **UPHILL** side of the crane where possible, especially when Articulated – **REMEMBER** the working Load Radius will increase if the load is suspended in the downhill position.
- Load swing greatly reduces stability – **REMEMBER** to tagline loads to prevent pendulum motion of the load. Travel and crane motions should be applied gently to minimise this effect.

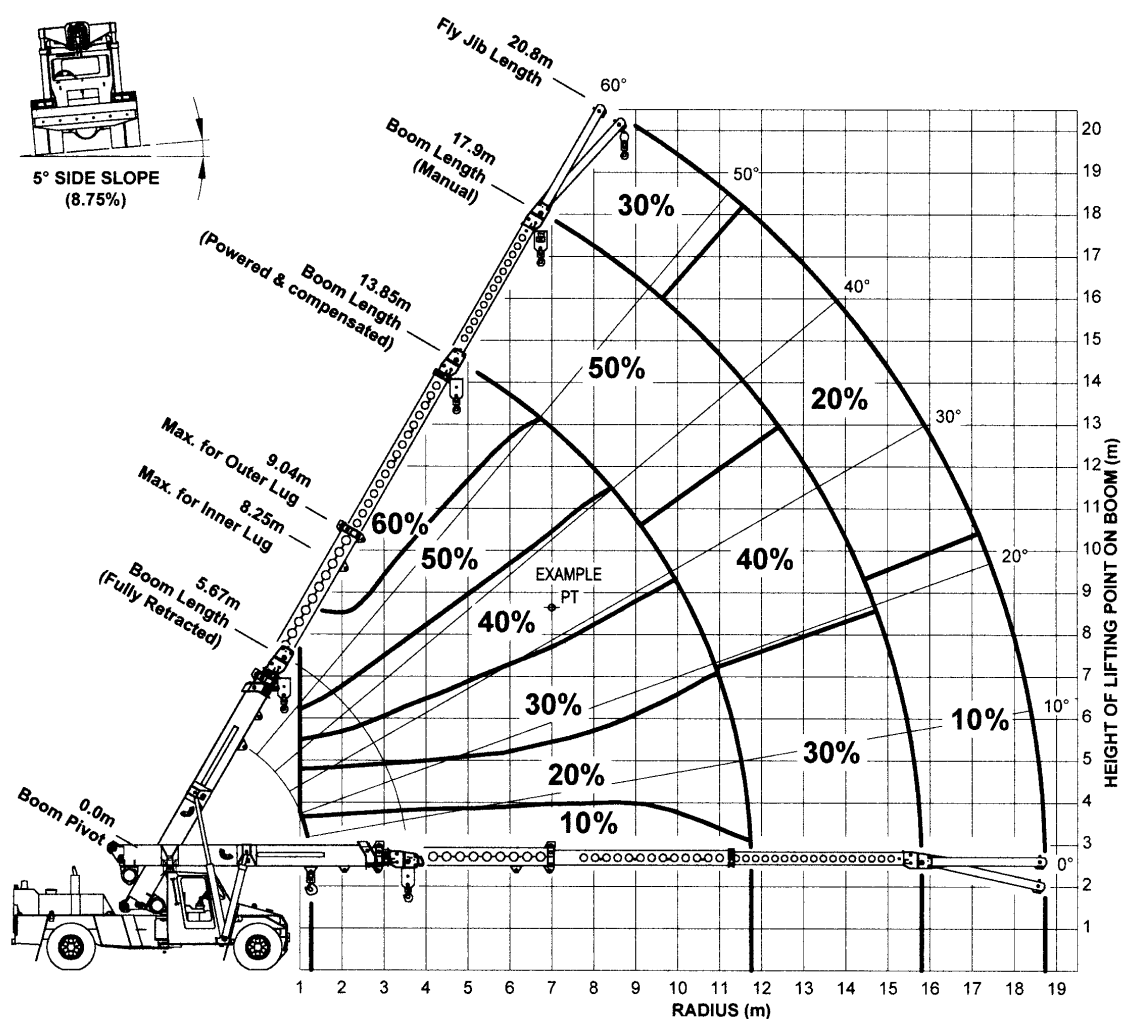

**Figure 1: Percentage Deration Chart for AT-20 at 5° Side Slope**

**Note:**

1. Percentage deration chart is based on 66.6% stability as per AS 1418.5 with the crane on a firm side slope of 5° (8.75% Gradient).
2. The percentage deration is dependent upon the location of the lifting point on the boom.
3. The percentage deration should be applied to the Rated Capacity as read off the Rated Capacity Manual for the applicable boom length, Loaded Boom Angle, Load Radius and Articulation angle.

**Example (For AT-20 Crane, Rated Capacity Manual 16C1320-):**

Lifting condition:	
Boom Length:	11.0 m
Loaded Boom Angle:	34.0°
Load Radius:	7.0 m
Articulation Angle:	Greater than 10°
RC (Level ground):	3750 kg (From Rated Capacity Manual LMI Duty 01, for above lifting conditions)
Percentage Deration:	40 % (From Figure 1: Percentage Deration Chart)
<b>RC (5° Slide Slope)</b>	$= \text{RC (as per Rated Capacity Manual)} - \text{Percentage Deration} \times \text{RC (as per Rated Capacity Manual)} / 100 \%$ $= 3750 \text{ kg} - 40\% \times 3750 \text{ kg} / 100\%$ $= \mathbf{2250 \text{ kg}}$

# **SECTION 2**

# **OPERATIONS**

RANGE DIAGRAM AT-20

WORKING AREA DIAGRAM

ATTACHMENT MASSES

HOOK BLOCK RC

TYRE SPECIFICATIONS

TYRE INFLATION CHART

# RANGE DIAGRAM AT-20

## SHOWING ALL LIFTING CONFIGURATIONS

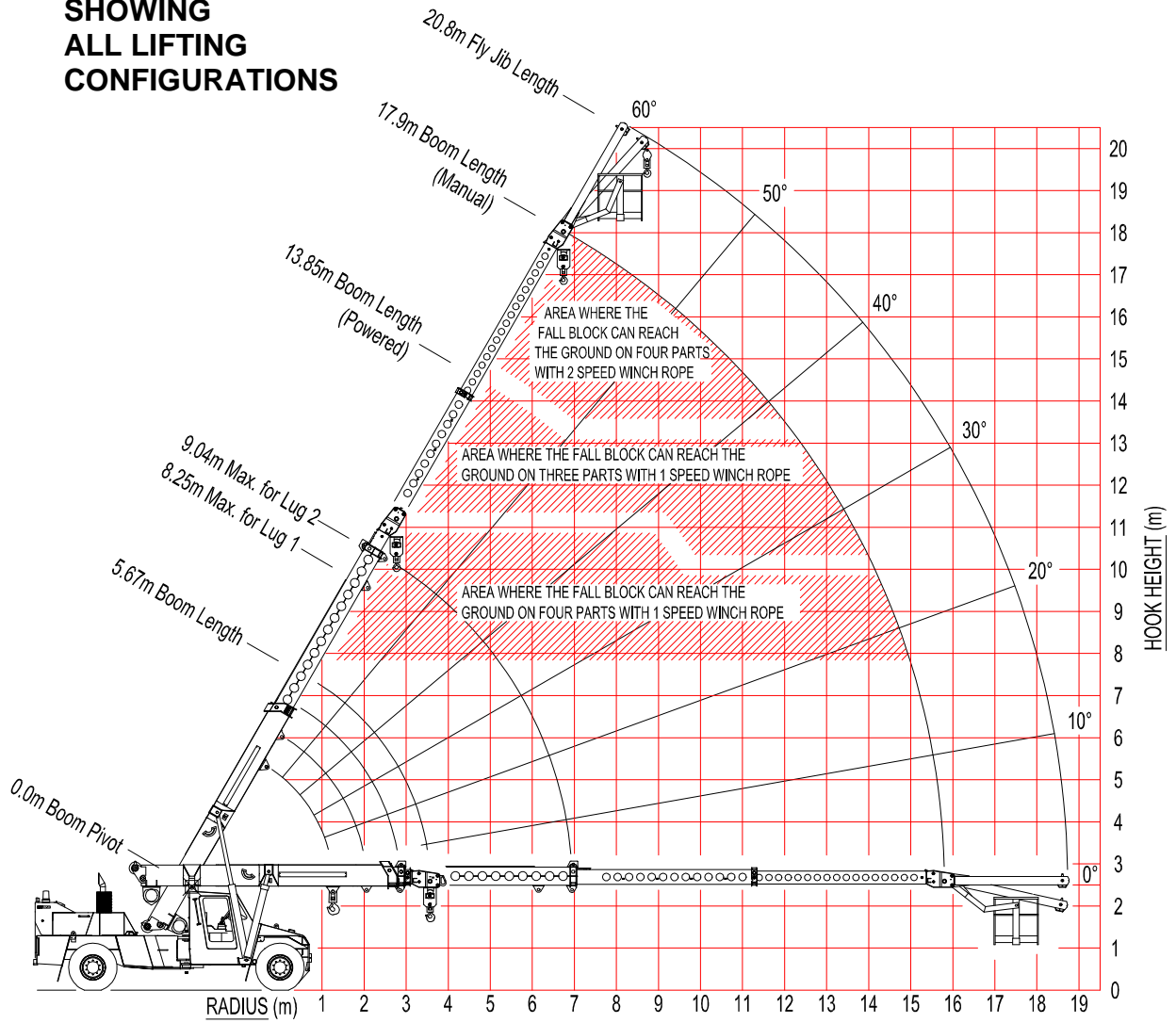

# WORKING AREA DIAGRAM

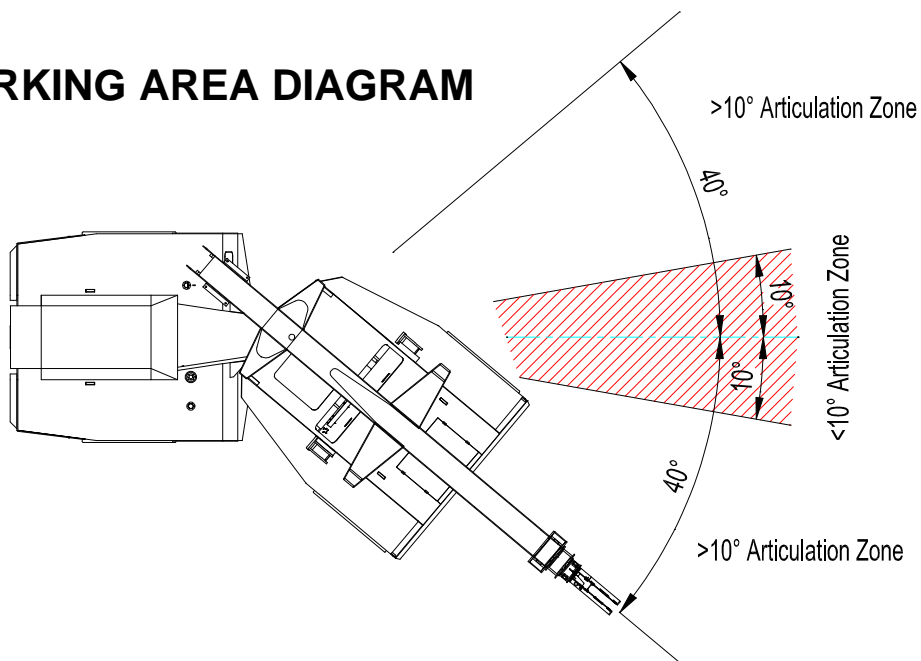

## ATTACHMENT MASSES

<b>SINGLE PART HOOK BLOCK</b>	<b>PL16M2090</b>	<b>30 kg</b>
<b>TWO/THREE PART HOOK BLOCK</b>	<b>PL16A3010</b>	<b>95 kg</b>
<b>FOUR PART HOOK BLOCK</b>	<b>PL16A3058</b>	<b>125 kg</b>
<b>FOUR PART HOOK BLOCK</b>	<b>PL16A3074</b>	<b>180 kg</b>
<b>20 METRIC TONNE HOOK</b>	<b>PP2190100</b>	<b>15 kg</b>
<b>12 METRIC TONNE SPREADER BAR</b>	<b>PL16A3035</b>	<b>110 kg</b>

**NOTE :** THESE MASSES APPLY ONLY TO TEREX LIFTING AUSTRALIA PTY LTD SUPPLIED EQUIPMENT.

## HOOK BLOCK RC

Number of Parts of Rope	Permissible Winch Load (kg)
1	4 200
2	8 400
3	12 600
4	16 800

**Wire Rope :** 14mm 35W x 7 Non-rotating Compak  
 Minimum Breaking Force 165 kN  
 1 Speed Winch - 65m  
 2 Speed Winch - 100m

## TYRE SPECIFICATIONS

Condition	Speed	Load Rating
Pick & Carry	<1.44 km/h	8680 kg per tyre at 120psi (dual fitment)
Highway	90 km/h	3000 kg per tyre at 100psi (dual fitment)

## TYRE INFLATION CHART

Position	Construction	Inflation Pressure – psi	
		Pick & Carry	Highway Travel
Front	12.00 x 20	120	120
Rear	12.00 x 20	100	100

# **SECTION 3**

## **LIFTING CAPACITY**

### **RANGE DIAGRAM (ALL LIFTS)**

LMI DUTY 01 : LIFTING CAPACITY ON WINCH -POWERED SECTIONS

LMI DUTY 03 : LIFTING CAPACITY ON WINCH –MANUAL EXTENSION

LMI DUTY 02 : LIFTING CAPACITY ON RHINO HOOK -POWERED SECTIONS

LMI DUTY 04 : LIFTING CAPACITY ON RHINO HOOK –  
MANUAL EXTENSION

LMI DUTY 05 : LIFTING CAPACITY ON FLYJIB  
(0° OFFSET) - POWERED SECTIONS

LMI DUTY 06 : LIFTING CAPACITY ON FLYJIB  
(0° OFFSET) - MANUAL EXTENSION

LMI DUTY 07 : LIFTING CAPACITY ON FLYJIB  
(12.5° OFFSET) - POWERED SECTIONS

LMI DUTY 08 : LIFTING CAPACITY ON FLYJIB  
(12.5° OFFSET) - MANUAL EXTENSION

LMI DUTY 09 : LIFTING CAPACITY ON FIXED LUG ON BUTT

LMI DUTY 10 : LIFTING CAPACITY ON INNER LUG ON FIRST EXT.

LMI DUTY 11 : LIFTING CAPACITY ON OUTER LUG ON FIRST EXT.

LMI DUTY 12 : LIFTING CAPACITY IN MAN BASKET –  
POWERED SECTIONS

LMI DUTY 13 : LIFTING CAPACITY IN MAN BASKET –  
MANUAL EXTENSION

# RANGE DIAGRAM AT-20

## SHOWING ALL LIFT CONFIGURATIONS

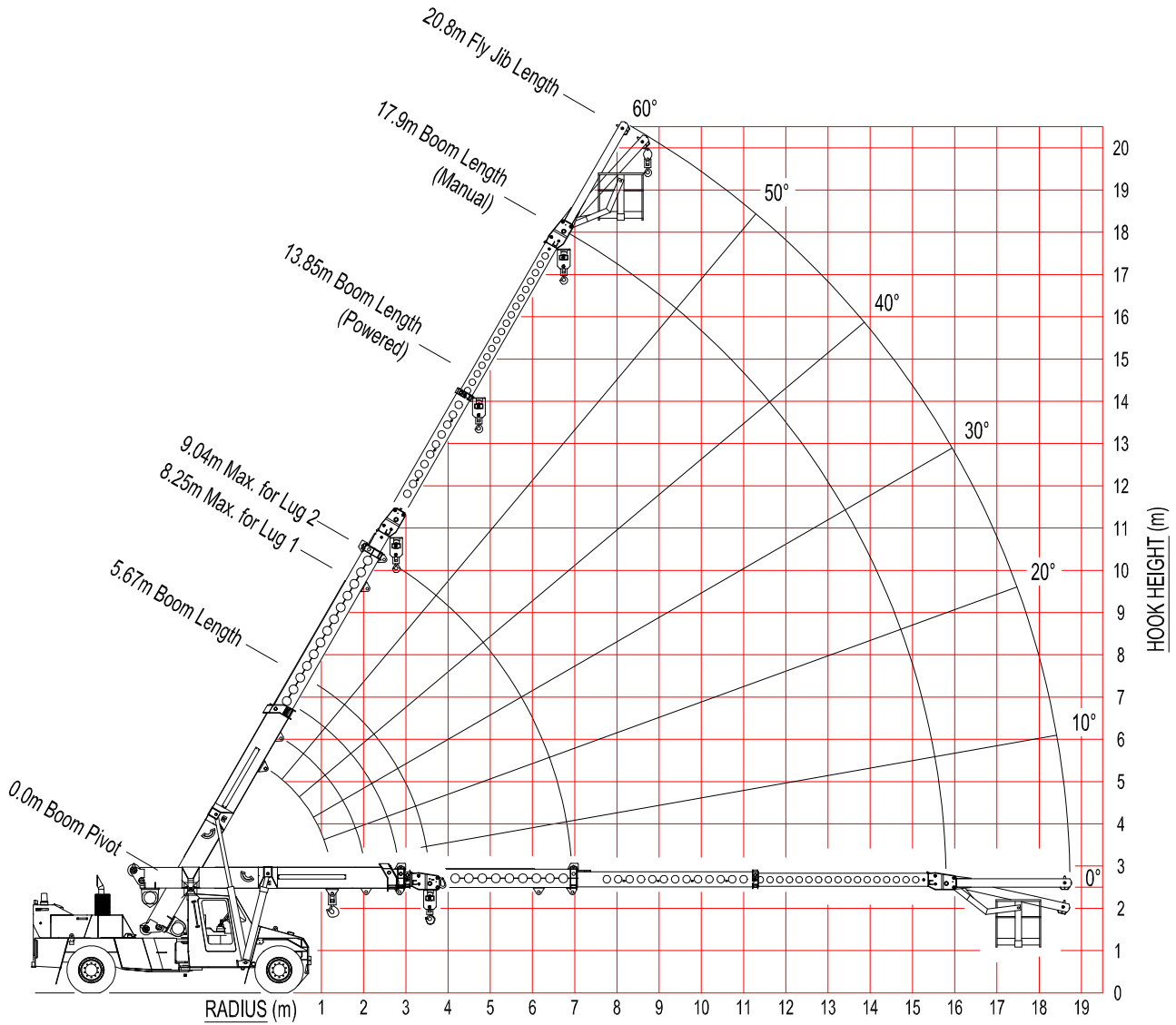

	RC (KG) LESS THAN 10 DEG ARTICULATION
	RC (KG) GREATER THAN 10 DEG ARTICULATION
	BOOM ANGLE OR (RADIUS AT 0 DEG BOOM ANGLE)

Mass of slings & hook block to be added to load  
Read and understand warning notes before operating crane  
Loads above bold red line are structural

RADIUS	BOOM LENGTH (m)																	
	5.67	6.00	6.50	7.00	7.50	8.00	8.50	9.00	9.50	10.00	10.50	11.00	11.50	12.00	12.50	13.00	13.50	13.85
1.6	16800	16250	15450	14900														
	12600	12600	12600	12600														
2.0	48	51	54	57														
	16800	16800	16500	15700	15100	14700	14350											
2.5	12600	12600	12600	12600	12600	12600	12600											
	42	46	50	53	56	58	60											
3.0	13900	13900	13900	13850	13850	13850	13200	13000										
	12150	12150	12100	12100	12100	12100	12050	12050										
3.5	34	39	44	48	51	54	56	58	60									
	11450	11450	11450	11400	11400	11400	11400	11400	11150	10250								
4.0	9950	9950	9950	9950	9950	9950	9900	9900	9900	9900								
	25	31	37	42	46	49	52	55	57	59	60							
4.5	9650	9650	9650	9650	9650	9650	9650	9650	9650	9650	9500	8150	7500					
	8400	8400	8400	8400	8400	8400	8400	8400	8350	8350	8350	8150	7500					
5.0	8	20	29	36	41	45	48	51	53	55	57	59	60					
	9450	8550	8350	8350	8350	8350	8350	8350	8300	8300	8300	7600	7000	6700	6450			
5.5	8200	7450	7250	7250	7250	7250	7250	7250	7200	7200	7200	7200	7000	6700	6450			
	(3.57)	(3.90)	19	28	35	39	43	47	49	52	54	56	57	59	60			
6.0		7500	7300	7300	7300	7300	7300	7300	7300	7300	7300	7150	6550	6250	6050	5800	5650	
		6500	6350	6350	6350	6350	6350	6350	6300	6300	6300	6300	6300	6250	6050	5800	5650	
6.5		(4.40)	19	27	34	38	42	45	48	50	52	54	56	58	59	60		
		6650	6500	6500	6500	6500	6500	6500	6500	6500	6500	6500	6500	6150	5900	5650	5450	5150
7.0				(4.90)	18	27	33	37	41	44	47	49	51	53	55	56	58	59
				5950	5250	5250	5250	5250	5250	5250	5250	5250	5250	5250	5250	5050	4850	4600
7.5				5100	4600	4550	4550	4550	4550	4500	4500	4500	4500	4500	4500	4500	4500	4500
				(5.40)	17	25	31	35	39	42	45	47	49	51	53	54		
8.0					4850	4450	4400	4400	4400	4400	4400	4400	4400	4400	4350	4350	4200	3950
					4200	3800	3750	3750	3750	3750	3750	3750	3750	3750	3750	3750	3750	3750
8.5					(6.40)	16	24	29	34	37	40	43	45	47	48			
						4100	3750	3700	3700	3700	3700	3700	3700	3700	3700	3700	3600	
9.0																		
9.5																		
10.0																		
10.5																		
11.0																		
11.75																		

	RC (KG) LESS THAN 10 DEG ARTICULATION
	RC (KG) GREATER THAN 10 DEG ARTICULATION
	BOOM ANGLE

*Mass of slings & hook block to be added to load*  
*Read and understand warning notes before operating crane*  
*Loads above bold red line are structural*

MANUAL EXT'D	
MAX LENGTH 17.90	
MAX RADIUS	RC
<b>6.74</b>	<b>2550</b>
	<b>2550</b>
<b>9.31</b>	<b>60</b>
	<b>2250</b>
	<b>2250</b>
<b>11.53</b>	<b>50</b>
	<b>2050</b>
	<b>2050</b>
<b>13.34</b>	<b>40</b>
	<b>1900</b>
	<b>1700</b>
<b>14.67</b>	<b>30</b>
	<b>1800</b>
	<b>1500</b>
<b>15.51</b>	<b>20</b>
	<b>1650</b>
	<b>1350</b>
<b>15.80</b>	<b>10</b>
	<b>1600</b>
	<b>1300</b>
	<b>0</b>

**NOTE :**  
 17.9m Boom length includes Manual 3rd extension.  
 Ratings for Manual extension are structural & based on Boom Angle, not radius. The ratings do not change if the power sections are retracted with the manual extended.

LMI Duty  
Lifting on RHINO HOOK

RC (KG) LESS THAN 10 DEG ARTICULATION
RC (KG) GREATER THAN 10 DEG ARTICULATION
BOOM ANGLE OR (RADIUS AT 0 DEG BOOM ANGLE)

Mass of slings & hook block to be added to load  
Read and understand warning notes before operating crane  
Loads above bold red line are structural

RADIUS	BOOM LENGTH (m)																	
	5.97	6.50	7.00	7.50	8.00	8.50	9.00	9.50	10.00	10.50	11.00	11.50	12.00	12.50	13.00	13.50	14.00	14.16
1.6	10000	10000	10000	10000														
2.0	10000	10000	10000	10000	10000	10000	10000	10000	10000	10000								
2.5	10000	10000	10000	10000	10000	10000	10000	10000	10000	10000	10000							
3.0	10000	10000	10000	10000	10000	10000	10000	10000	10000	10000	10000							
3.5	9750	9750	9750	9700	9700	9700	9700	9700	9700	9650	8850	7650						
4.0	8500	8500	8450	8450	8450	8450	8450	8450	8400	8400	8400	7650						
4.5	8700	8400	8400	8400	8400	8400	8350	8350	8350	8350	8100	7100	6750	6500				
5.0	7550	7300	7300	7300	7300	7300	7250	7250	7250	7250	7100	6750	6500					
5.5	(3.88)	19	29	35	40	43	47	49	52	54	56	57	59	60				
6.0	7550	7400	7400	7350	7350	7350	7350	7350	7350	7350	7350	6650	6300	6100	5850	5700		
6.5	6550	6400	6400	6400	6400	6400	6350	6350	6350	6350	6350	6350	6300	6100	5850	5700		
7.0	(4.40)	19	28	34	38	42	45	48	50	53	54	56	58	59	60			
7.5	6700	6550	6550	6550	6550	6550	6550	6550	6550	6550	6500	6250	5950	5700	5500	5350	5150	5100
8.0	5800	5650	5650	5650	5650	5650	5650	5650	5650	5650	5650	5650	5600	5600	5500	5350	5150	5100
8.5	(4.90)	18	27	33	37	41	44	47	49	51	53	55	56	58	59	59	59	59
9.0	6000	5400	5300	5300	5300	5300	5300	5300	5300	5300	5300	5300	5300	5100	4900	4750	4600	4550
9.5	5150	4650	4550	4550	4550	4550	4550	4550	4550	4550	4550	4550	4550	4550	4550	4550	4550	4550
10.0	(5.40)	17	25	31	35	39	42	45	47	49	51	53	54	55	55	55	55	55
10.5	4900	4500	4400	4400	4400	4400	4400	4400	4400	4400	4400	4400	4400	4400	4400	4250	4000	3950
11.0	4200	3850	3800	3800	3800	3800	3800	3800	3800	3800	3800	3800	3800	3800	3750	3750	3750	3750
11.5	(6.40)	16	24	29	34	37	40	43	45	47	49	51	53	54	55	55	55	55
12.0	4100	3800	3750	3750	3750	3750	3750	3750	3750	3750	3750	3750	3750	3750	3750	3600	3550	3550
12.5	3550	3250	3200	3200	3200	3200	3200	3200	3200	3200	3200	3200	3200	3200	3200	3200	3200	3200
13.0	(7.40)	15	23	28	32	36	39	41	43	44	44	44	44	44	44	44	44	44
13.5	3500	3250	3250	3250	3250	3250	3250	3250	3250	3250	3250	3250	3250	3250	3250	3250	3250	3250
14.0	3000	2800	2750	2750	2750	2750	2750	2750	2750	2750	2750	2750	2750	2750	2750	2750	2750	2750
14.5	(8.40)	14	22	27	31	34	37	40	43	45	47	49	51	53	54	55	55	55
15.0	3050	2850	2800	2800	2800	2800	2800	2800	2800	2800	2800	2800	2800	2800	2800	2800	2800	2800
15.5	2600	2400	2400	2400	2400	2400	2400	2400	2400	2400	2400	2400	2400	2400	2400	2400	2400	2400
16.0	(9.40)	14	21	26	30	33	36	39	41	43	44	44	44	44	44	44	44	44
16.5	2650	2500	2500	2500	2500	2500	2500	2500	2500	2500	2500	2500	2500	2500	2500	2500	2500	2500
17.0	2250	2100	2100	2100	2100	2100	2100	2100	2100	2100	2100	2100	2100	2100	2100	2100	2100	2100
17.5	(10.40)	14	20	25	29	32	35	38	40	42	44	46	48	50	52	54	56	58
18.0	2350	2200	2200	2200	2200	2200	2200	2200	2200	2200	2200	2200	2200	2200	2200	2200	2200	2200
18.5	1950	1850	1850	1850	1850	1850	1850	1850	1850	1850	1850	1850	1850	1850	1850	1850	1850	1850
19.0	(11.40)	14	19	24	28	31	34	37	40	43	45	47	49	51	53	55	57	59
19.5	2350	2200	2200	2200	2200	2200	2200	2200	2200	2200	2200	2200	2200	2200	2200	2200	2200	2200
20.0	1950	1850	1850	1850	1850	1850	1850	1850	1850	1850	1850	1850	1850	1850	1850	1850	1850	1850
20.5	(11.40)	14	19	24	28	31	34	37	40	43	45	47	49	51	53	55	57	59
21.0	2350	2200	2200	2200	2200	2200	2200	2200	2200	2200	2200	2200	2200	2200	2200	2200	2200	2200
21.5	1950	1850	1850	1850	1850	1850	1850	1850	1850	1850	1850	1850	1850	1850	1850	1850	1850	1850
22.0	(11.40)	14	19	24	28	31	34	37	40	43	45	47	49	51	53	55	57	59
22.5	2350	2200	2200	2200	2200	2200	2200	2200	2200	2200	2200	2200	2200	2200	2200	2200	2200	2200
23.0	1950	1850	1850	1850	1850	1850	1850	1850	1850	1850	1850	1850	1850	1850	1850	1850	1850	1850
23.5	(11.40)	14	19	24	28	31	34	37	40	43	45	47	49	51	53	55	57	59
24.0	2350	2200	2200	2200	2200	2200	2200	2200	2200	2200	2200	2200	2200	2200	2200	2200	2200	2200
24.5	1950	1850	1850	1850	1850	1850	1850	1850	1850	1850	1850	1850	1850	1850	1850	1850	1850	1850
25.0	(11.40)	14	19	24	28	31	34	37	40	43	45	47	49	51	53	55	57	59
25.5	2350	2200	2200	2200	2200	2200	2200	2200	2200	2200	2200	2200	2200	2200	2200	2200	2200	2200
26.0	1950	1850	1850	1850	1850	1850	1850	1850	1850	1850	1850	1850	1850	1850	1850	1850	1850	1850
26.5	(11.40)	14	19	24	28	31	34	37	40	43	45	47	49	51	53	55	57	59
27.0	2350	2200	2200	2200	2200	2200	2200	2200	2200	2200	2200	2200	2200	2200	2200	2200	2200	2200
27.5	1950	1850	1850	1850	1850	1850	1850	1850	1850	1850	1850	1850	1850	1850	1850	1850	1850	1850
28.0	(11.40)	14	19	24	28	31	34	37	40	43	45	47	49	51	53	55	57	59
28.5	2350	2200	2200	2200	2200	2200	2200	2200	2200	2200	2200	2200	2200	2200	2200	2200	2200	2200
29.0	1950	1850	1850	1850	1850	1850	1850	1850	1850	1850	1850	1850	1850	1850	1850	1850	1850	1850
29.5	(11.40)	14	19	24	28	31	34	37	40	43	45	47	49	51	53	55	57	59
30.0	2350	2200	2200	2200	2200	2200	2200	2200	2200	2200	2200	2200	2200	2200	2200	2200	2200	2200
30.5	1950	1850	1850	1850	1850	1850	1850	1850	1850	1850	1850	1850	1850	1850	1850	1850	1850	1850
31.0	(11.40)	14	19	24	28	31	34	37	40	43	45	47	49	51	53	55	57	59
31.5	2350	2200	2200	2200	2200	2200	2200	2200	2200	2200	2200	2200	2200	2200	2200	2200	2200	2200
32.0	1950	1850	1850	1850	1850	1850	1850	1850	1850	1850	1850	1850	1850	1850	1850	1850	1850	1850
32.5	(11.40)	14	19	24	28	31	34	37	40	43	45	47	49	51	53	55	57	59
33.0	2350	2200	2200	2200	2200	2200	2200	2200	2200	2200	2200	2200	2200	2200	2200	2200	2200	2200
33.5	1950	1850	1850	1850	1850	1850	1850	1850	1850	1850	1850	1850	1850	1850	1850	1850	1850	1850
34.0	(11.40)	14	19	24	28	31	34	37	40	43	45	47	49	51	53	55	57	59
34.5	2350	2200	2200	2200	2200	2200	2200	2200	2200	2200	2200	2200	2200	2200	2200	2200	2200	2200
35.0	1950	1850	1850	1850	1850	1850	1850	1850	1850	1850	1850	1850	1850	1850	1850	1850	1850	1850
35.5	(11.40)	14	19	24	28	31	34	37	40	43	45	47	49	51	53	55	57	59
36.0	2350	2200	2200	2200	2200	2200	2200	2200	2200	2200	2200	2200	2200	2200	2200	2200	2200	2200
36.5	1950	1850	1850	1850	1850	1850	1850	1850	1850	1850	1850	1850	1850	1850	1850	1850	1850	1850
37.0	(11.40)	14	19	24	2													

	RC (KG) LESS THAN 10 DEG ARTICULATION
	RC (KG) GREATER THAN 10 DEG ARTICULATION
	BOOM ANGLE

*Mass of slings & hook block to be added to load*  
*Read and understand warning notes before operating crane*  
*Loads above bold red line are structural*



<b>MANUAL EXT'D</b>	
<b>MAX LENGTH 18.20</b>	
<b>MAX RADIUS</b>	<b>RC</b>
	<b>2400</b>
<b>6.91</b>	<b>2400</b>
	<b>60</b>
	<b>2100</b>
<b>9.52</b>	<b>2100</b>
	<b>50</b>
	<b>1900</b>
<b>11.78</b>	<b>1900</b>
	<b>40</b>
	<b>1800</b>
<b>13.62</b>	<b>1650</b>
	<b>30</b>
	<b>1750</b>
<b>14.97</b>	<b>1450</b>
	<b>20</b>
	<b>1550</b>
<b>15.81</b>	<b>1350</b>
	<b>10</b>
	<b>1550</b>
<b>16.11</b>	<b>1300</b>
	<b>0</b>

**NOTE :**  
 18.2m Boom length includes Manual 3rd extension.  
 Ratings for Manual extension are structural & based on Boom Angle, not radius. The ratings do not change if the power sections are retracted with the manual extended.

**LMI Duty**  
Lifting on FLYJIB (0 offset)

**05**

FLYJIB	
MAX LENGTH 16.78	
MAX RADIUS	RC
6.23	1500
	1500
	60
8.62	1200
	1200
	50
10.69	970
	970
	40
12.38	850
	850
	30
13.63	770
	770
	20
14.40	750
	750
	10
14.68	750
	750
	0

 RC (KG) LESS THAN 10 DEG ARTICULATION  
 RC (KG) GREATER THAN 10 DEG ARTICULATION  
 BOOM ANGLE



*Mass of slings & hook block to be added to load*  
*Read and understand warning notes before operating crane*  
*Loads above bold red line are structural*

**NOTE :**  
 16.78m Boom length includes Flyjib.  
 Ratings for Flyjib are structural & based on Boom Angle, not radius. The ratings do not change if the power sections are retracted with the Flyjib installed.

**LMI Duty**  
Lifting on FLYJIB (0 offset)  
**MANUAL EXTENDED**

**06**

MANUAL EXT'D	
MAX LENGTH 20.83	
MAX RADIUS	RC
8.25	1500
	1500
	60
11.22	1200
	1200
	50
13.79	970
	970
	40
15.88	850
	850
	30
17.43	770
	770
	20
18.39	750
	750
	10
18.73	750
	750
	0

 RC (KG) LESS THAN 10 DEG ARTICULATION  
 RC (KG) GREATER THAN 10 DEG ARTICULATION  
 BOOM ANGLE

*Mass of slings & hook block to be added to load*  
*Read and understand warning notes before operating crane*  
*Loads above bold red line are structural*

**NOTE :**  
 20.83m Boom length includes Manual 3rd extension & Flyjib. Ratings for Flyjib are structural & based on Boom Angle, not radius. The ratings do not change if the power sections are retracted with the manual extended and Flyjib installed.

## LMI Duty

# 07

Lifting on FLYJIB (12.5 deg offset)

FLYJIB	
MAX LENGTH 16.74	
MAX RADIUS	RC
6.70	1500
	1500
9.03	60
	1200
	1200
11.03	50
	970
	970
12.63	40
	850
	850
13.78	30
	770
	770
14.46	20
	750
	750
14.64	10
	750
	750
	0

	RC (KG) LESS THAN 10 DEG ARTICULATION
	RC (KG) GREATER THAN 10 DEG ARTICULATION
	BOOM ANGLE

*Mass of slings & hook block to be added to load  
Read and understand warning notes before  
operating crane*

*Loads above bold red line are structural*

### NOTE :

16.74m Boom length includes Flyjib.  
Ratings for Flyjib are structural & based  
on Boom Angle, not radius. The ratings do not  
change if the power sections are retracted with  
the Flyjib installed.

## LMI Duty

# 08

Lifting on FLYJIB (12.5 deg offset)

MANUAL EXTENDED

MANUAL EXT'D	
MAX LENGTH 20.79	
MAX RADIUS	RC
8.73	1300
	1300
11.64	60
	1120
	1120
14.13	50
	920
	920
16.14	40
	820
	820
17.59	30
	770
	770
18.45	20
	750
	750
18.69	10
	750
	750
	0

	RC (KG) LESS THAN 10 DEG ARTICULATION
	RC (KG) GREATER THAN 10 DEG ARTICULATION
	BOOM ANGLE

*Mass of slings & hook block to be added to load  
Read and understand warning notes before  
operating crane*

*Loads above bold red line are structural*

### NOTE :

20.79m Boom length includes Manual 3rd extension  
& Flyjib. Ratings for Flyjib are structural & based  
on Boom Angle, not radius. The ratings do not  
change if the power sections are retracted with  
the manual extended and Flyjib installed.

	RC (KG) LESS THAN 10 DEG ARTICULATION
	RC (KG) GREATER THAN 10 DEG ARTICULATION
	BOOM ANGLE

*Mass of slings & hook block to be added to load*  
*Read and understand warning notes before operating crane*  
*Loads above bold red line are structural*

FIXED LUG	
BOOM LENGTH 3.36	
MAX RADIUS	RC
	<b>20000</b>
	<b>20000</b>
	30
<b>0.86</b>	<b>20000</b>
	<b>20000</b>
	20
<b>1.09</b>	<b>20000</b>
	<b>20000</b>
	10
<b>1.23</b>	<b>20000</b>
	<b>20000</b>
	0
<b>1.26</b>	<b>20000</b>
	<b>20000</b>
	<b>0</b>

Mass of slings & hook block to be added to load  
Read and understand warning notes before operating crane  
Loads above bold red line are structural

	RC (KG) LESS THAN 10 DEG ARTICULATION
	RC (KG) GREATER THAN 10 DEG ARTICULATION
	BOOM ANGLE OR (RADIUS AT 0 DEG BOOM ANGLE)

RADIUS	BOOM LENGTH (m)								
	4.16	4.50	5.00	5.50	6.00	6.50	7.00	7.50	8.25
1.4	20000	20000	20000	19300	18100	17200			
	16000	16000	16000	16000	16000	16000			
	34	40	46	51	55	58			
1.7	19000	19000	19000	18700	17600	16500	15600	15000	
	16000	16000	16000	16000	16000	16000	15600	15000	
	25	33	41	47	51	55	58	60	
2.0	16950	16900	16800	16700	16650	16000	14650	14100	
	14750	14700	14600	14500	14400	14350	14300	14100	
	11	25	36	43	48	52	55	57	
2.5	16400	13800	13150	13100	13050	12950	12900	12750	11350
	14300	11950	11400	11350	11250	11200	11150	11100	11050
	(2.06)	(2.40)	24	34	41	46	50	53	57
3.0			11100	10700	10650	10600	10550	10500	10450
			9600	9200	9150	9100	9050	9000	8950
			(2.90)	23	33	39	44	48	52
3.5				9200	8900	8850	8800	8800	8750
				7900	7650	7600	7550	7500	7450
				(3.40)	22	31	38	42	48
4.0					7800	7550	7550	7500	7450
					6700	6450	6450	6400	6350
					(3.90)	21	30	36	43
4.5						6700	6550	6500	6450
						5700	5550	5500	5500
						(4.40)	20	29	37
5.0							5850	5700	5650
							4950	4800	4800
							(4.90)	19	31
5.5								5150	5000
								4350	4200
								(5.40)	23
6.0									4450
									3700
									11
6.15									4300
									3600
									(6.15)

Mass of slings & hook block to be added to load  
Read and understand warning notes before operating crane  
Loads above bold red line are structural



	RC (KG) LESS THAN 10 DEG ARTICULATION
	RC (KG) GREATER THAN 10 DEG ARTICULATION
	BOOM ANGLE OR (RADIUS AT 0 DEG BOOM ANGLE)

RADIUS	BOOM LENGTH (m)								
	4.95	5.30	5.80	6.30	6.80	7.30	7.80	8.30	9.04
1.4	20000	20000	20000	19900					
	16000	16000	16000	16000					
	46	50	54	57					
1.7	19000	19000	19000	18850	17400	15650			
	16000	16000	16000	16000	16000	15650			
	41	45	50	54	57	59			
2.0	17400	17300	17150	17050	16350	14700	13400		
	15200	15100	14950	14850	14750	14650	13400		
	35	40	46	50	54	56	59		
2.5	13700	13600	13500	13400	13300	13250	12350	11150	10150
	11950	11850	11750	11650	11550	11500	11400	11150	10150
	23	31	38	44	48	52	54	57	60
3.0	11850	11150	11050	11000	10900	10850	10750	10300	9350
	10300	9700	9600	9500	9450	9350	9300	9250	9150
	(2.85)	17	29	37	42	46	50	53	56
3.5		10350	9300	9250	9150	9100	9050	9000	8650
		9000	8050	8000	7900	7850	7800	7750	7650
		(3.20)	16	28	35	41	45	48	52
4.0			8700	7900	7850	7800	7750	7700	7650
			7550	6800	6750	6700	6650	6600	6550
			(3.70)	15	27	34	39	43	48
4.5				7450	6850	6800	6750	6700	6650
				6400	5850	5800	5750	5750	5650
				(4.20)	15	26	33	38	44
5.0					6500	6000	5950	5900	5850
					5550	5100	5050	5000	4950
					(4.70)	14	25	32	39
5.5						5700	5250	5250	5200
						4850	4450	4450	4400
						(5.20)	14	24	33
6.0							5050	4700	4650
							4250	3950	3900
							(5.70)	13	27
6.5								4500	4200
								3750	3500
								(6.20)	19
6.9									3800
									3150
									(6.94)

**LMI Duty**  
Lifting in MANBASKET

**12**

MANBASKET	
MAX LENGTH 13.85	
MAX RADIUS	RC
<b>6.06</b>	<b>275</b>
	<b>275</b>
	<b>60</b>
<b>8.24</b>	<b>275</b>
	<b>275</b>
	<b>50</b>
<b>10.10</b>	<b>275</b>
	<b>275</b>
	<b>40</b>
<b>11.59</b>	<b>275</b>
	<b>275</b>
	<b>30</b>
<b>12.67</b>	<b>275</b>
	<b>275</b>
	<b>20</b>
<b>13.30</b>	<b>275</b>
	<b>275</b>
	<b>10</b>
<b>13.46</b>	<b>275</b>
	<b>275</b>
	<b>0</b>

 RC (KG) LESS THAN 10 DEG ARTICULATION  
 RC (KG) GREATER THAN 10 DEG ARTICULATION  
 BOOM ANGLE



*Read and understand warning notes before operating crane*  
*Loads above bold red line are structural*

**NOTE :**  
 13.85m Boom length does not include Manbasket. Ratings for Manbasket are structural & based on Boom Angle, not radius. The ratings do not change if the power sections are retracted with the Manbasket installed.

**LMI Duty**  
Lifting in MANBASKET  
MANUAL EXTENDED

**13**

MANUAL EXT'N	
MAX LENGTH 17.90	
MAX RADIUS	RC
<b>8.09</b>	<b>275</b>
	<b>275</b>
	<b>60</b>
<b>10.85</b>	<b>275</b>
	<b>275</b>
	<b>50</b>
<b>13.21</b>	<b>275</b>
	<b>275</b>
	<b>40</b>
<b>15.10</b>	<b>275</b>
	<b>275</b>
	<b>30</b>
<b>16.46</b>	<b>275</b>
	<b>275</b>
	<b>20</b>
<b>17.29</b>	<b>275</b>
	<b>225</b>
	<b>10</b>
<b>17.51</b>	<b>275</b>
	<b>205</b>
	<b>0</b>

 RC (KG) LESS THAN 10 DEG ARTICULATION  
 RC (KG) GREATER THAN 10 DEG ARTICULATION  
 BOOM ANGLE

*Read and understand warning notes before operating crane*  
*Loads above bold red line are structural*

**NOTE :**  
 17.90m Boom length includes Manual 3rd extension but not Manbasket. Ratings for Manbasket are structural based on Boom Angle, not radius. The ratings do not change if the power sections are retracted with the manual extended and Manbasket installed.

